



# SG0611/E2

## High-Temperature Instrumentation Amplifier Evaluation Board

### ◆ DESCRIPTION

Evaluation board for SG0611, High-Temperature Instrumentation Amplifier circuit.

The board is manufactured using high-temperature components suitable for evaluation up to +225°C. Separate connection board for easy access to signals at room temperature.

With the default configuration of the board it is possible to instantly evaluate a high-temperature application with a gain from 18x to 278x.

### ◆ KEY FEATURES

- Instant evaluation of a high-temperature application
- High-temperature materials capable of more than +225°C
- Low temperature connection board for sensor and supply with removable terminals for easy access
- Gain selection by jumpers
- Flexible modifications are possible

### ◆ OVERVIEW

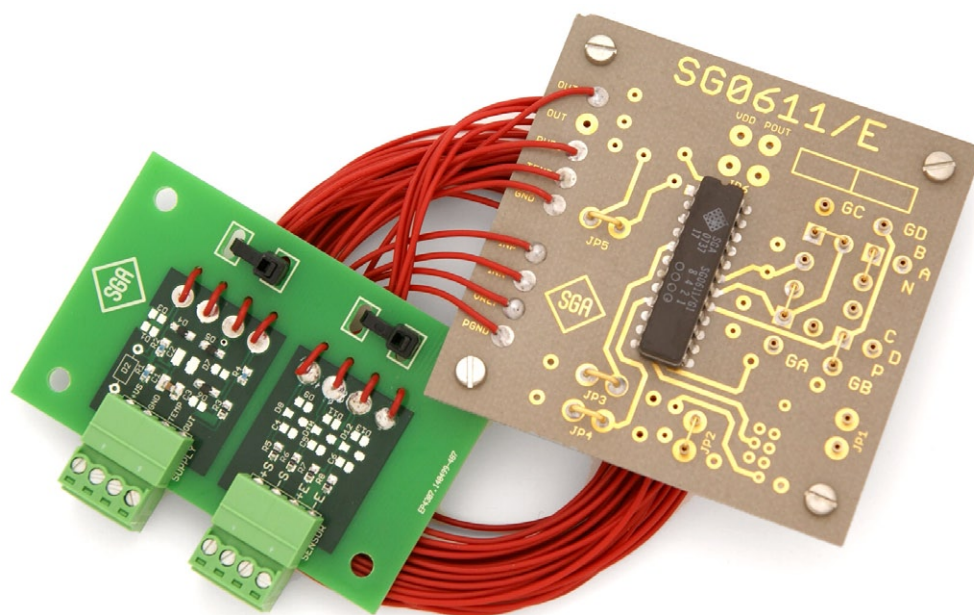



# SG0611/E2

## ◆ FUNCTIONAL DESCRIPTION

The board is equipped with a minimum of components for a normal application. Space is provided to mount extra resistors and capacitors for more detailed evaluation. See the section below for modifications.

The extra connection board includes terminals for supply, signal and sensor. Recommended overvoltage protection and filtering is added to the board. The connection board is made in materials for normal temperatures and should be placed in room temperature.

Sensor connections for higher temperatures can be done by cutting the wires and mount other terminals, or solder the sensor directly to the PCB.

The high-temperature PCB is manufactured using Taconic RF35 with a  $T_g=+315^\circ\text{C}$ . Solder with  $+270^\circ\text{C}$  melting point and PTFE isolated wires capable of  $+260^\circ\text{C}$  have been used to make the evaluation board capable of an evaluation temperature of  $+225^\circ\text{C}$ .

## ◆ CONNECTION DIAGRAM

This simplified schematics shows the complete evaluation board, including the extra connection board. The Supply, +VS, should be kept between  $+20$  to  $+32\text{V}$ .

Keep the sensor current below  $15\text{mA}$ . It is supplied from the internal voltage reference at  $+5\text{V}$ . This voltage is also used to supply the amplifier, which will deliver an output signal of from close to  $0\text{V}$  up to  $+4.5\text{V}$ .

The internal temperature measuring diode can be connected if needed, the current should be limited to  $1\text{mA}$ . The temperature coefficient is approximately  $-5\text{mV}/^\circ\text{C}$ . This is the internal temperature of the SG0611 die and will read a larger temperature than the environment due to the self-heating from the other parts on the device.

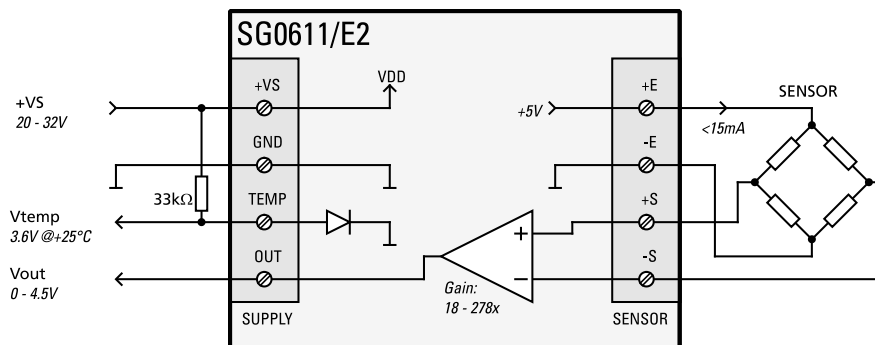

Simplified diagram of the evaluation board together with the connection board.



# SG0611/E2

## ◆ BOARD MODIFICATIONS

There are plenty of possibilities to modify the evaluation board to evaluate all the features in SG0611. Changes in the sensor supply, offset adjustments and filtering is made by cutting jumpers, place resistors and capacitors.

Note that special high-temperature solder has been used and is needed for evaluation. See the placement drawing and diagram below.

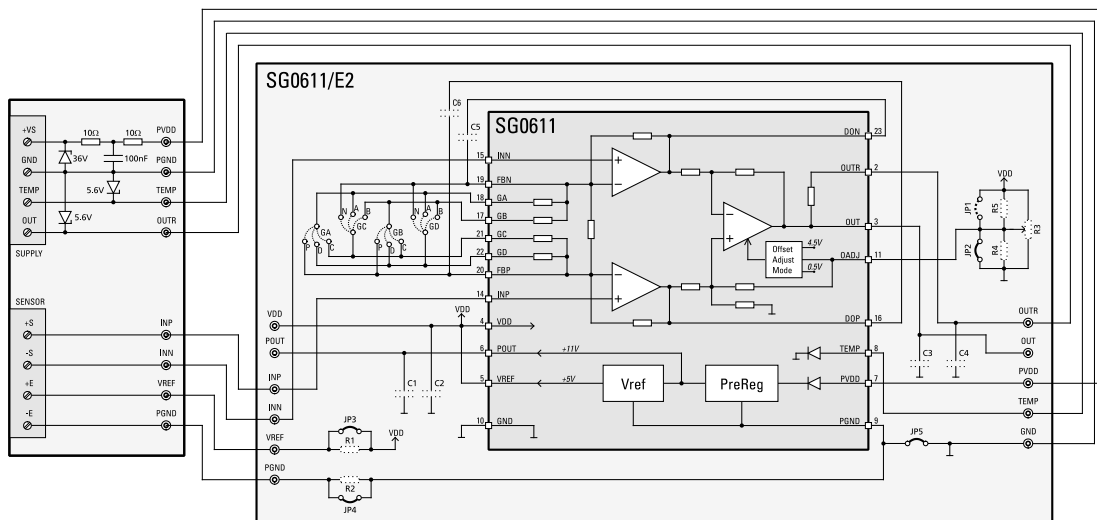
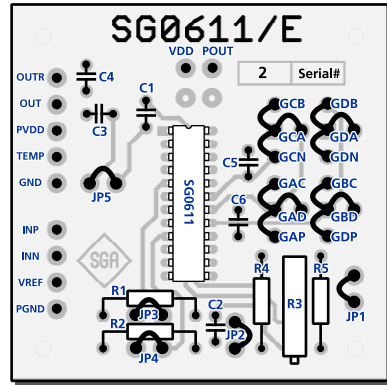

Complete diagram of the board. Optional components not mounted are shown with dashed lines.

### Gain setting table

The gain can be selected in 41 steps by placing jumpers as shown in the following table:

Gain	Links	Gain	Links	Gain	Links	Gain	Links
18.0	None	71.3	GAC+GBC	112.5	GAC+GBP+GDA	178.0	GAP+GBP
31.3	GBD	72.5	GAC+GDA	115.1	GAD+GCN	184.7	GAP+GBC+GDN
35.1	GAD	75.1	GAD+GBP	115.8	GAD+GBD+GCN	198.0	GAP+GBP+GDN
35.8	GAD+GBD	78.0	GBP+GDN	118.0	GCN+GDN	218.0	GAP+GCN
38.0	GDN	79.3	GAC+GBD	126.0	GAC+GBP+GDN	231.3	GAP+GBD+GCN
44.7	GBC	79.5	GAC+GBD+GCB	138.0	GAP	238.0	GAP+GCN+GDN
46.6	GBC+GDB	86.0	GAC+GDN	151.3	GAP+GBD	258.0	GAP+GBP+GCN
58.0	GBP	91.3	GAC+GBC+GDN	155.1	GAD+GBP+GCN	278.0	GAP+GBP+GCN+GDN
61.8	GAD+GBC	98.0	GCN	158.0	GAP+GDN		
64.7	GBC+GDN	106.0	GAC+GBP	164.7	GAP+GBC		
66.0	GAC	111.3	GBD+GCN	166.6	GAP+GBC+GDB		



◆ SALES CONTACT

***Please visit our website [www.sga.se](http://www.sga.se)  
for more information about our  
representatives and distributors,  
or contact SGA directly.***

***specific***   
***components***

Svenska Grindmatriser AB  
Brigadgatan 16  
SE-581 31 Linköping  
Sweden

Phone: +46 13 36 46 60  
Fax: +46 13 36 46 61  
E-mail: [info@sga.se](mailto:info@sga.se)  
[www.sga.se](http://www.sga.se)

◆ INFORMATION

**Additional information and support**

If you need any technical advice or help in any way regarding this product, please send an E-mail to [support@sga.se](mailto:support@sga.se), or call SGA, +46 13 364660, and ask for support. We will always be pleased to discuss your requirements and how this product could be used in your application.

**Electrostatic discharge (ESD) precautions**

Electrostatic Discharge (ESD) can damage this integrated circuit. SGA recommends that all integrated circuits is handled with appropriate precautions. Failure to observe proper handling may cause performance degradation or complete failure.

**Data sheet identification**

**Advance Information**

The product is in a formative or design stage. The data sheet contains target specifications for product development. Engineering samples may or may not be available.

**Preliminary Specification**

The data sheet contains preliminary data. Additional data may be added later. Engineering samples are available. Production quantities may or may not be available.

**Product Specification**

The data sheet contains final product specifications. The product is in full production.

**Notice**

Svenska Grindmatriser AB (SGA) believes the information contained in this data sheet to be correct and accurate at the time of printing. However, SGA assumes no liability for the use of this information. Use shall be entirely at the user's own risk.

Svenska Grindmatriser AB (SGA) reserves the right to make changes without further notice to the product to improve reliability, function or design. SGA does not assume any liability arising out of the application or use of any product or circuits described herein.

© 2005 Svenska Grindmatriser AB.  
All rights reserved